

MS STRAPPING TOOL

© Panduit Corp. 2013

INTRODUCTION

The BT2HT Tool installs Panduit Pan-Steel coated and uncoated MS Series strap and buckles in widths of 3/8" X .015" thick (9.5mm), 1/2" X .015" thick (12.7mm); and 5/8" X .015" and .025" thick (15.9mm).

Note: This tool is not intended for other uses such as cutting or tensioning other types of fastening devices.

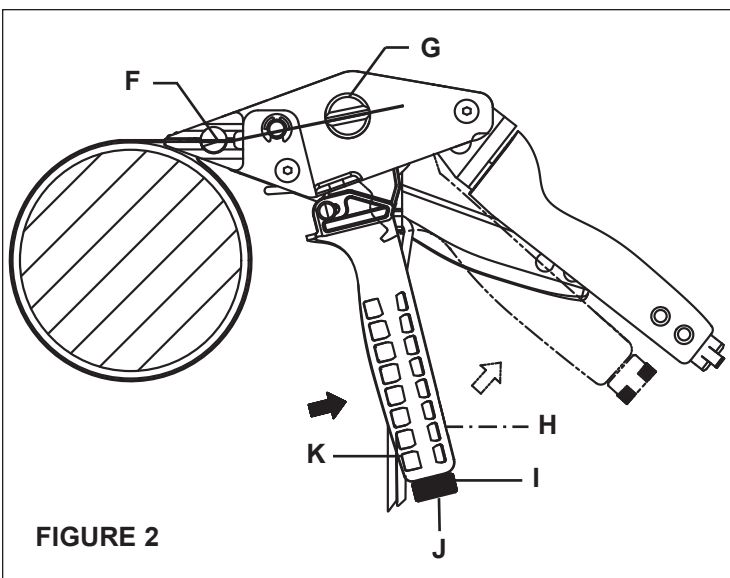
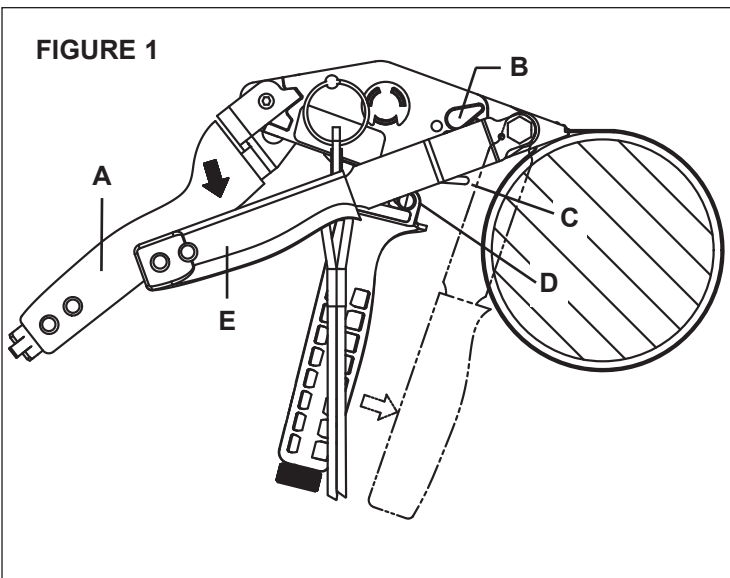
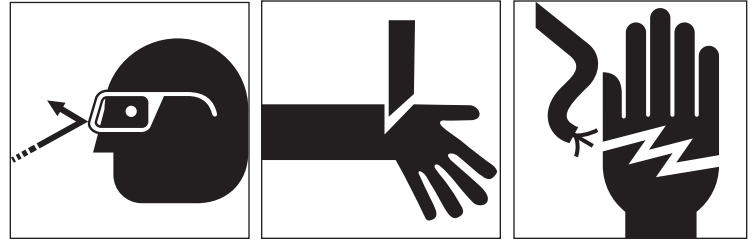

TOOL FEATURES

- A. Rear Handle
- B.* Tension Pawl Release - Knob pointing towards the front of tool for pawl engagement and to rear of tool for disengagement.
- C.* Anti-Backup Pawl Release - Lever up against tool for pawl engagement and pulled down to disengage pawl.
- D.* Detent Lock Pins - For controlled tension, pull both pins forward; for manual tension, push both pins backward.
- E. Cutter Handle - Cuts tie when strap is tensioned properly.
- F. Cutter Blade
- G. Tensioning Mandrel
- H.* Tension Indicator Window - Located on the back of front handle.
- I.* Adjustment Knob - Adjust tension of strap application.
- J. Tension Locking Set Screw
- K. Front Handle - With ratchet controlled tensioning.

* See Page 2 for Feature Detail

TOOL OPERATION

See Steps 1 - 8 on Pages 3 and 4.

E-mail:
techsupport@panduit.com

PANDUIT
www.panduit.com

Technical Support:
888-506-5400, ext. 83255

TOOL MAINTENANCE

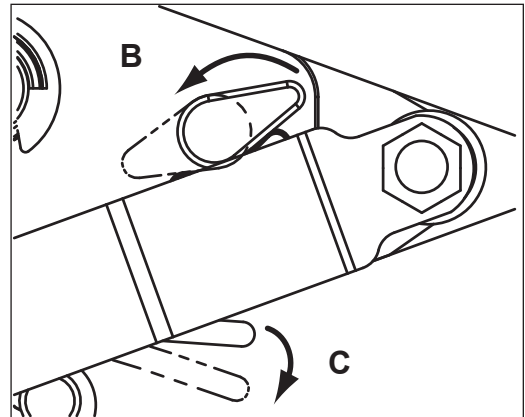
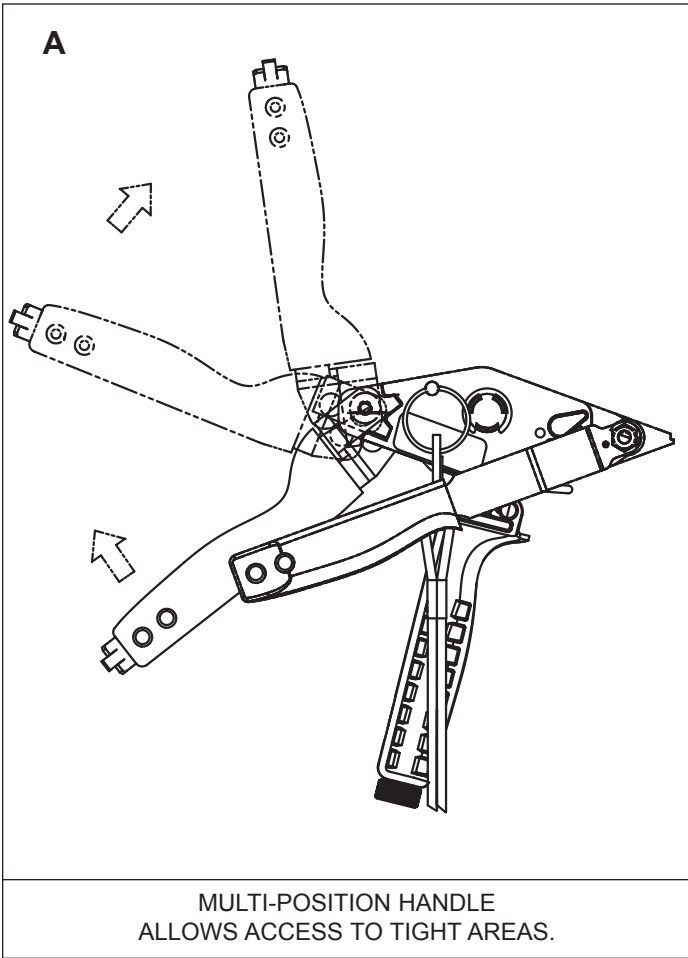

TO INHIBIT CORROSION AND MAINTAIN PERFORMANCE OF THE TOOL, KEEP THE METAL SURFACES COATED WITH A LIGHT OIL (WD-40® OR EQUIVALENT).



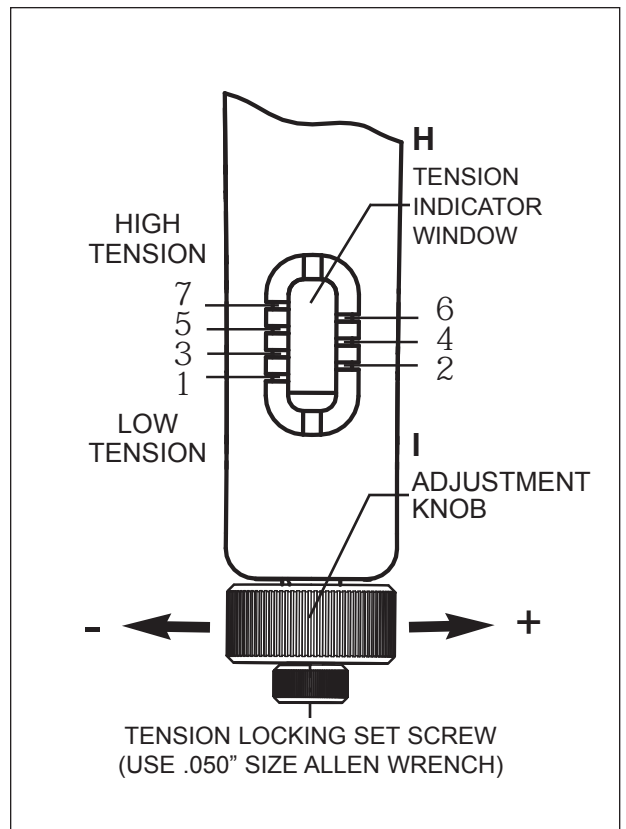
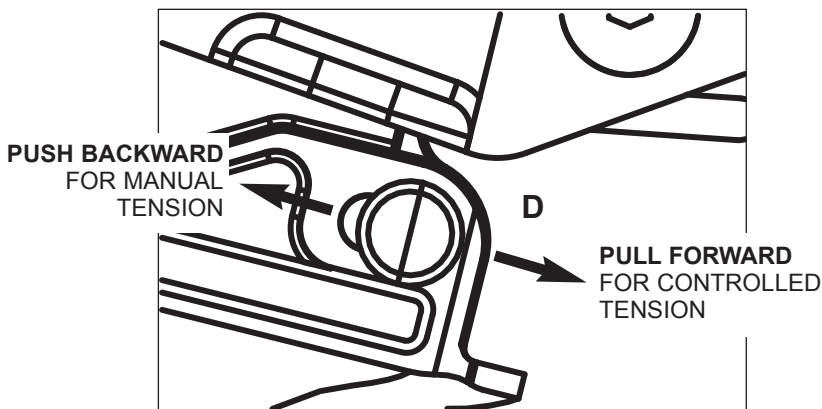

TROUBLESHOOTING
TO RELEASE AND REMOVE STRAP FROM TOOL BEFORE CUTTING, DISENGAGE BOTH KNOB AND LEVER.

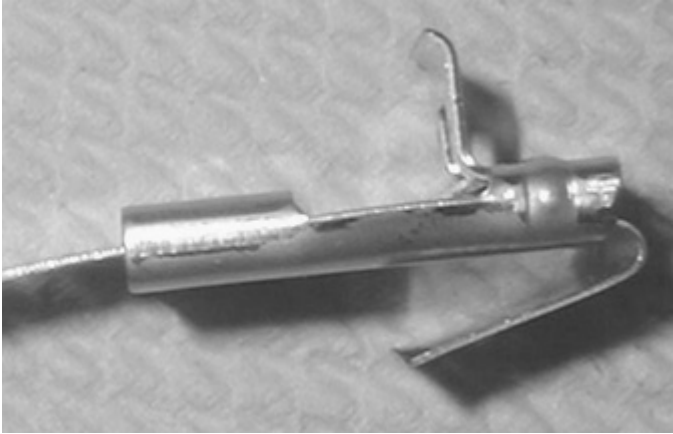
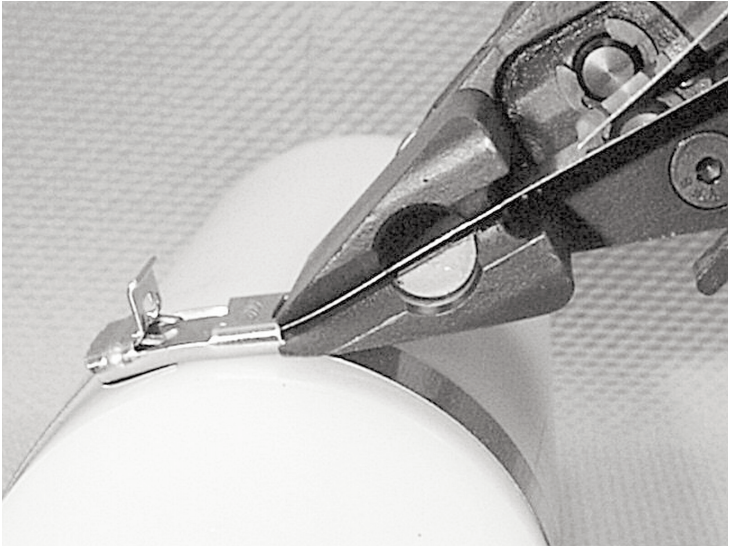
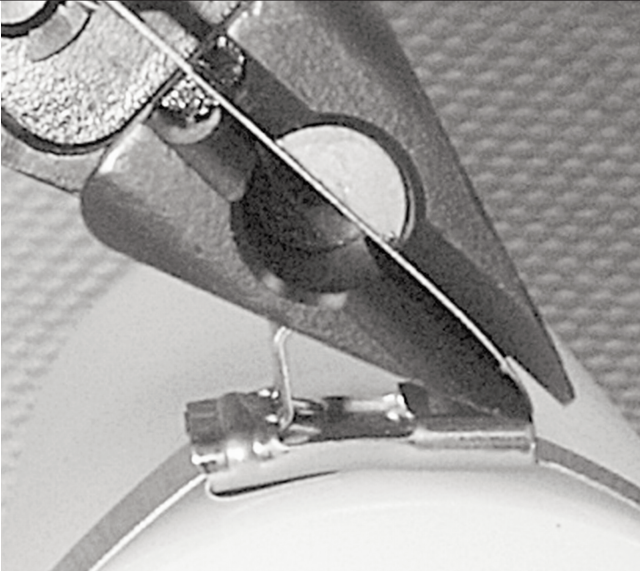

STRAP SIZE	SETTING
3/8" STRAP	1 – 5
1/2" STRAP	1 – 7
5/8" STRAP	1 – 7

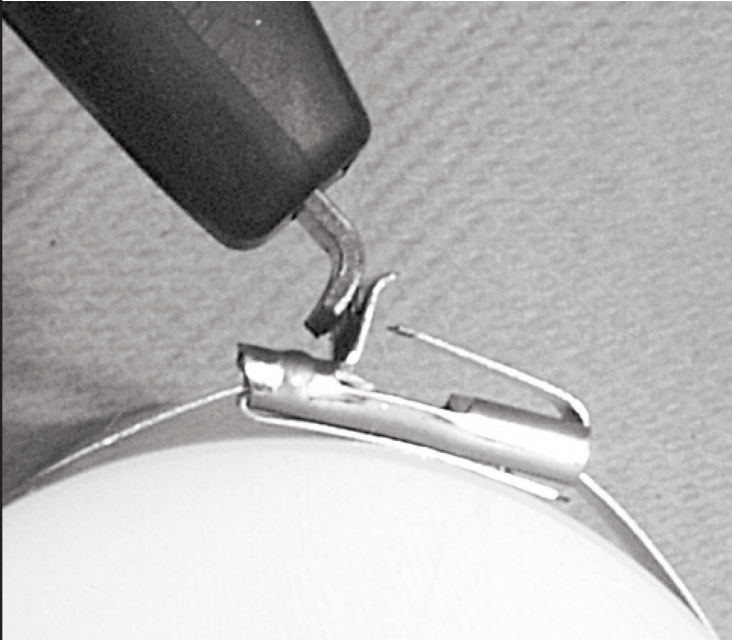
STEP 1	STEP 2
	
<p>Slide in buckle and bend the end of strap.</p>	<p>Loop strap around bundle. Thread strap into nose of tool and through slot of tensioning mandrel.</p>
STEP 3	STEP 4
	
<p>Pull front handle to tension strap and rotate the tool to touch the buckle (as shown).</p> <p>Under controlled tension, the front handle will break free when pre-determined tension is attained.</p>	<p>Push cutter lever downward to cut strap. Remove cut-off portion of strap from tool.</p>

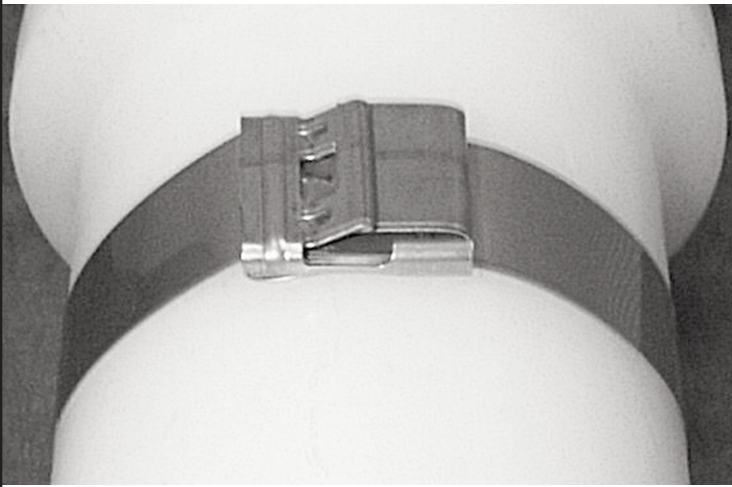
STEP 5	STEP 6
	
<p>Bend cut-off end of strap down.</p>	<p>Position tab of the tool inside the buckle slot.</p>
STEP 7	STEP 8
	
<p>Bend the buckle <u>lock</u> down as shown.</p>	<p>Strap correctly installed.</p>